



Cotswold Gliding Club

New Member's Guide



Version 6.0 May 2026 MJW

Copyright © Cotswold Gliding Club 2026

Welcome

Welcome to the Cotswold Gliding Club.

This guide is to help you get the most from your membership. It explains the basics of the way we operate and gives some details of club organisation.

If you have any problems or need to know something please do not hesitate to ask.

Contacts

The club office phone number is 01285 702100. Our office administrator Susi Cernoch works from 9am to 2pm. At other times there is an answer phone.

You can also email her at office@cotswoldgliding.co.uk.

The Chairman can be contacted at chairman@cotswoldgliding.co.uk

The Chief Flying Instructor can be contacted at cfi@cotswoldgliding.co.uk

The club house phone number is 01285 702101. This is the pay phone at the top of the stairs and is useful to check up on the local weather and to see if we are flying or not.

The Launch Point Bus phone number is 01285 702103

The club's website is at www.cotswoldgliding.co.uk. Please note that there is a member's area where items of interest to members are posted, you will need to request access to this area, this can be done by registering as a new member on the website.

Operating Times

From April through to September we run a 7 day operation.

During the winter months the club operates on weekends, Wednesdays and other days when the weather is favourable.

Website

On a day-to-day basis the website should be your regular port of call for information. This can be found at www.cotswoldgliding.co.uk. You will find a member's area on the site. Once you have registered as a member on the site you will have access to all of the club's documentation including the ability to book instruction and refer to operations manuals. You also have access to view your account status.

The club also has two Yahoo groups for discussion between members of relevant subjects. We have a main group for general discussion and also a development group for flying subjects and cross-country flight planning. You are free to join both of these and they are a great way of staying in touch with goings on at the club. Please feel free to make comments. Links to both are found on the website.

Getting Started – The Basics

If you are completely new to gliding, please read this section.

One day course

We strongly recommend that you start by attending a one-day introductory course. These courses are restricted to a maximum of two pupils, a dedicated two-seater and instructor. This means you will get a full day's flying to get you started and we will be able to give you a proper briefing on airfield operations and safety. If you have already joined the club, you will only be required to pay the normal flying fees for the flights you have. To book yourself on a course please contact Susi in the office.

Paper work

When you join the club, you should be issued with following:

- A log book to record your flying – your instructors will also make notes in here.
- A progress card covering the gliding syllabus – your instructors will complete this card as you progress.
- A Ground Instruction Checklist.

- **Club Rules**

Please make sure you have your logbook and white card on your person when you fly with an instructor. He/she will want to look at your logbook and card before any instructional flight.

Planning your flying

When you are learning to fly it is best to try and fly as regularly as you can to stay in practice. Most students progress well by flying at least one day a week, this way you will stay in practice and gain experience of flying in a variety of conditions. If you leave it two or three weeks between visits you may find that your first one or two flights will be taken up with getting back to where you left off.

Similarly, a good way of progressing your flying is to attend a week's course in the spring or summer. Most pilots find they progress well over five days of solid flying.

Instruction – how it works

When you arrive at the club, the first thing to do is put your name on the flying list. This will be available at the morning briefing. When flying starts, the Duty Instructor(s) will take pupils in order from the list. When it is your turn, you will normally have three flights at a time or the soaring equivalent (15 minutes soaring = one launch). When you have had your three flights, you can put your name back on the list and if time and demand allow, you may fly again.

A good tip to help you progress well is to turn up early (9.00am or so) on your flying days. This should mean you fly promptly and will have a good chance of a second set of flights later in the day. You'll also learn more about club operations.

The club also operates an online booking system called Click n Glide which is accessible from the club website, here you can book specific instruction slots and specify the type of instruction that you require.

Pitching in - what the club expects from you

Gliding is a team effort and we rely on each other to get airborne. You won't be expected to do everything straight away, but by asking an experienced member to show you, you can quickly become a useful member of the launch point team. Things that you should aim to learn in your first few days include:

- retrieving gliders;

- hooking on the cable and signalling the launch;
- operating the lights;
- driving the retrieve car.

The best way to learn about these items is to take a one-day course where they are covered in detail.

In general, when you come to fly you should plan stay for at least half a day to help out, i.e. if you arrive early, aim to stay until the early afternoon, if you come later in the day, aim to stay until the gliders are packed away.

The club also operates a Duty Team system and upon joining the club you will be allocated to one of the three teams – Red, White or Blue. Each team has its own co-ordinator who will make contact at various stages to find out availability for forthcoming duty weekends which run on a three-week cycle. Each member is expected to take part in one day's duty every six weeks. The system is fairly flexible so it is quite possible to swap around if you can't make a particular duty day. You should also have no trouble flying during your duty day.

Your team co-ordinator is a good point of contact for you regarding ground operations and if they don't know the answer to your question, they will know someone who does. If you are not sure about anything, please do not hesitate to ask.

You are encouraged to get involved on the airfield when not flying. You will get to know other members more quickly and feel a part of the club. The more members that we get involved also helps us to keep our costs down and our launch frequency up which benefits everyone.

Paying for your flying

Each member has an account to which your membership, flying fees and any other payments are charged. You must not let your account go overdrawn and unfortunately, we have to apply financial penalties if you allow your account to remain in arrears. Payments can be made by cash or cheque (payable to Cotswold Gliding Club) and posted in the letter box in the office. Many members arrange a standing order into their account to cover their flying fees. Any surplus can then go towards your annual membership. If you want to do this then Susi will give you the necessary bank details.

Your account status can also be accessed from the club website using the link at "My Flying Account".

Club Organisation

Committee

The club is run by a committee elected by the club members. The committee usually consists of:

- Chairman
- Deputy Chairman
- Secretary
- Treasurer
- Marketing Officer
- Chief Flying Instructor (co-opted)

Instructors

Our instructors are all unpaid volunteers. The duty instructors are allocated to a team which rotates every 3 weeks. Instruction can be booked by using the link on the club website to the booking system.

These are the instructor ratings and their privileges:

- Basic Instructor. Can teach the elementary flying exercises but not launching or landing.
- Assistant Instructor. Can teach all exercises to solo standard.
- Full Instructor. As above but can also conduct written and flight tests for the various gliding awards.

Club year

The club year runs from October 1st. This is when membership fees are due and the annual flying hour's returns are made. The club Annual General Meeting usually takes place in January.

Medical standards

Currently medical standards for gliding are similar as for driving. Solo pilots must have a medical, the minimum being a PMD (Pilot Medical Declaration)

Forms and information can be found at

[Medical information - Pilot & Club Info](#)

You are also required to be responsible for your fitness to fly on any given day. We all have our off days and sometimes it would be better to stay at home. A useful mnemonic to remember the problems that may arise is IMSAFE:

- **Illness.** If you're ill or under the weather don't fly. You'll feel worse in the air.
- **Medication.** Many drugs, either prescribed, over the counter or illicit will make you unfit to fly. Make sure your doctor knows you are a pilot.
- **Sleep.** Do not fly if you're tired or have not had enough sleep.
- **Alcohol.** Leave at least 8 hours between consuming even small quantities of alcohol and flying. The limits for flying are a quarter of that for driving - 20 milligrams of alcohol per 100 millilitres of blood,
- **Food.** Eat sensibly and don't miss meals. Take something to eat and drink on a long flight. It is vital to guard against dehydration.
- **Environment.** Wear clothing appropriate for the temperatures expected in the air. Protect yourself from the sun.

The donation of blood will make you temporarily unfit to fly.

Guided Tour

Club house

The clubhouse door has a combination lock. Please ask someone to tell you the combination and how to work the lock. The club house is otherwise known as the tower.

Office

There's a post box in the wall to deliver flying fees etc. when the office is shut. We also have a selection of gliding merchandise and books for sale.

Store

In the store we keep parachutes, glider batteries and their chargers, barographs and various items of spare hardware for the launch cable assemblies.

Briefing Room

Here you will find:

- **The Flight Operations Manual. Every member must read this book.** There is a section in the book for you to sign once it has been read and a condition of membership is that it is read annually.
- NOTAMs (NOTices to Airmen) a publication that tells us about temporary airspace restrictions and other navigation warnings. Pilots who are flying cross-country are expected to read these when planning their flight.
- A computer with Internet access. This has software for flight planning and downloading flight logs from recorders carried in gliders. We use the Internet for getting NOTAMs, weather forecasts, submitting flight claims, getting documents from the BGA etc, etc. Please don't abuse this facility and bear in mind that use of the Internet is monitored.
- Various notices regarding airfield and flying operations.
- Maps for flight planning.

Lavatories and Showers

Please leave them as you would expect to find them. Cleaning materials are available.

Kitchen

The facilities in the kitchen are available for club members to prepare their own meals. You will also find tea and coffee, drinks, sandwiches, snacks, crisps, and pre-prepared meals available for purchase. Prices are posted in the kitchen and you should pay for your anything you use immediately. Please ask someone to show you how to work the till. Please wash up or place your items in the dishwasher after you have finished.

Bar

The bar is opened in the evening after flying has finished.

Bunkrooms

Bunkrooms are available for members and can be booked through the office.

Other Buildings and Property

Hangar

The hangar door has a combination lock. You will need to get someone to tell you the combination. The hangar holds all the club gliders and most of the vehicles. There are also a limited number of glider places available for club members to rent.

The Butts

This is the structure between the workshop and hangar, which was used for test firing aircraft guns. This is where we keep the bus, winches, retrieve trucks and other equipment.

Workshop

The workshop is locked with a key held in the club office. This is where we keep glider spares such as tyres, oils and greases and do most of the vehicle and glider maintenance. Members may rent the workshop for the maintenance of their own gliders.

Airfield

The gliding club owns most of the land inside the perimeter track with the areas that we don't own used by local farmers. The large ex MOD hangars are leased for industrial and storage use. Walkers, horses, cars, tractors and commercial vehicles use the perimeter track.

A Flying Day

We try to start flying as early as possible and so you should try to arrive at about 9am to help get everything ready. If you arrive later then you should stay and help put the kit away at the end of the day.

The first thing to do when arriving is to get your name on the flying list. This determines the order in which gliders are allocated to pilots. The list is written on a white board kept on the bus which, at this time of day, may still be parked in the butts.

The next job is to unpack the hangar. It requires at least three people to get a glider out and should only be done with the help of a suitably experienced club member. The hangar can be packed very tightly and removing the gliders requires some care. More damage is done to gliders in the hangar than anywhere else. The scratches and dents picked up in the hangar are referred to as "hangar rash". Once removed from the hangar the glider should be parked on the grass. Don't leave it immediately outside the hangar because you will need somewhere to put the gliders still in the hangar. The duty instructor will decide how many gliders are required, with due regard to the number of members present and the weather conditions.

Vehicles

With the exception of the Golf Buggies, only full flying members may drive the club vehicles and they must hold a full driving licence. Each vehicle is given a daily inspection before it is used which includes a check on fuel, oil, coolant and tyres. A club member will be able to show you this. Before driving any of the vehicles please get someone to show you. None of the vehicles are completely straightforward and all have a few quirks, which you need to be aware of. The winch uses LPG from the tank by the tower. You should make sure you've seen the refuelling done several times before doing it yourself. Even then you should have a more experienced person on hand for the first few times. The diesel tank for the vehicles and tractors is next to the gas tank near the tower. The tank has a lock and the key is available from the clubhouse, please note any diesel usage.

The Launch Point Vehicle (Charlie) will be inspected and driven to the launch point. The battery is recharged via a cable plugged into Charlie, forgetting to unplug the cable before driving away is not a good start to the day.

Moving a glider

The diagram shows the points on a glider that are strong enough to manoeuvre the glider.

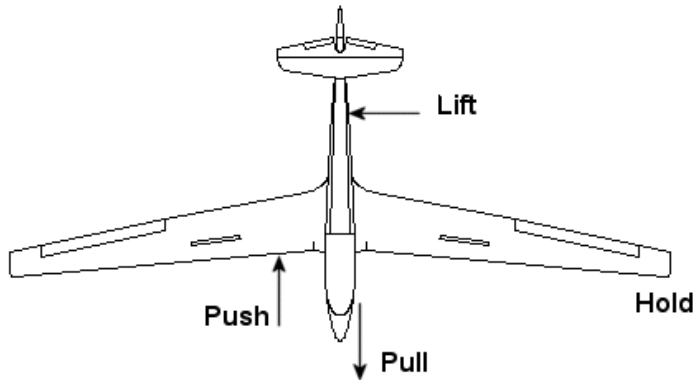

We can:

- Pull on the cockpit rim and on the straps (with the canopy open).
- Push on the leading edge of the wing.
- Lift by the handles on the rear fuselage.
- Hold a wingtip to rotate and steer the glider.

We never:

- Lift the glider by the tail plane.
- Push on the trailing edge of the wing.
- Handle the control surfaces.

When moving a glider, we always have someone holding the up-wind wingtip to steer. We rarely need someone on both wingtips. When turning a glider, you need to be aware that you may need to change the wingtip being held as the free tip comes into wind. If someone is on the ball then they will have positioned themselves ready to take the wing. Otherwise, someone will shout something like “change wings”. When changing wings the first wingtip holder will shout “your wing” and the second wingtip holder should respond with “my

wing". This way we always know who has control and we don't end up with two people fighting one another, or even worse, no one holding a wingtip.

Parking a glider

To park a glider, we use tyres to weigh the glider down and stop it moving. If the wind is light and the glider is being left temporarily, say on the launch queue, it is sufficient to have the wing most into wind weighted by a single tyre. If we are leaving a glider unattended then we park the glider as shown in the diagram.

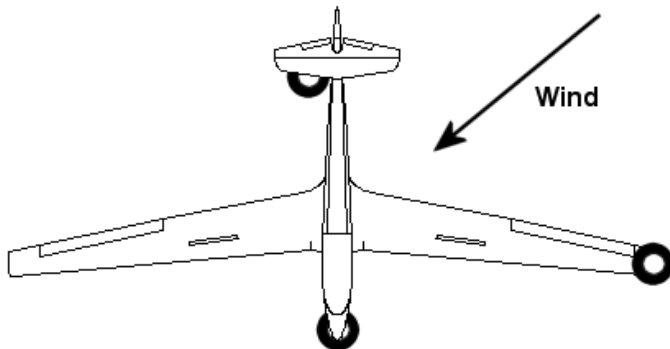

We place tyres:

- On the upwind wingtip to weigh it down.
- Under the nose to stop the glider moving forward.
- On the downwind side of the tail wheel or skid to stop the tail blowing round.

If the wind is strong then we will use more tyres on the wingtip. In very windy conditions we may have to stay with the glider continuously and hold it down ourselves.

We also have to consider the slope of the ground. It may be necessary to chock the wheel to stop the glider rolling backwards.

Glider canopies can cost thousands of pounds. Never leave a canopy open or unlocked because the wind can easily slam it shut and break it.

Daily Inspections

We give all gliders a daily inspection (DI) before they are flown. This task is undertaken by more experienced pilots who are authorised to do the job, although newer members will be able to assist. In particular we do a positive control check to ensure the control connections are secure. This involves applying pressure to the control surfaces while the cockpit control is moved and obviously requires two people. When a daily inspection is being carried out, please don't distract the person doing the inspection.

Daily inspections are recorded in a DI book kept in the pocket in the cockpit. If the glider is unserviceable then the book is left open on the glider seat to make it obvious.

Winch

The winch will be inspected, refuelled and driven to the upwind end of the runway in use. Someone trained as a winch driver normally does this. The winch driver will need a retrieve truck taken to the winch to tow out the cables. New members can do this once they have been shown how.

Parachutes

Parachutes sufficient for the number of seats in club gliders are taken from the parachute store in the tower. Parachutes are vital safety equipment and we should take great care of them. They must never get damp - if this happens, they may not open correctly. Transport them in their bags and leave them on the shelf in Charlie just to the right of the door. Please make sure that the shelf is dry before leaving them there. Never place them on the ground. All parachutes are numbered and should be kept in the corresponding bag.

Towing Out

After the gliders have been inspected, they have to be taken to the launch point, which we do by towing the glider with a buggy or a car. The rules for towing are:

- Attach the rope to the belly hook and not the nose hook. The nose hook doesn't have a back release.
- We always have one person walking with the in-to-wind wing tip.
- We always have one person walking beside the nose of the glider who is there to stop the glider when the buggy stops. The easiest way to do this is by pushing on the wing leading edge, usually with your bottom. Never try to stop the glider moving by placing your hand in the opening in the glider canopy.

- Drive with the window open and radio off. You need to be able to hear people asking you to stop.
- The rope should be more than half the span of the glider so that if the glider rotates while on tow the wing tip won't hit your car.

To release the rope from the glider, use the back release. Get someone to show you how this works if you're not sure. **Never put your hand through the canopy to use the cockpit release knob because you risk damaging the canopy.**

Don't drive a car with a rope trailing because the rope won't follow the path taken by the car and can easily snag on a glider.

We also have a trailer for moving the K13s, which is useful when flying from the south end. More experienced members will know how to load the trailer.

Private Vehicles

If you take your car to the launch point please park it in the correct place. At the north end, this is on the runway well behind the launch point. At the south end the parking is on the grass outside the perimeter track on the west side.

When driving on the airfield:

- Please keep to the 30-mph speed limit when driving round the airfield. It's also important to keep your speed down on the entrance lane to the airfield. There are several houses here and children frequently play in the lane.
- Most motor insurance policies have an airside exclusion which means you are not covered when driving on the airfield. Top up insurance is available from aviation insurers if you're unhappy with the exclusion.
- When driving on the perimeter track, please be aware that gliders can land from any direction. Keep a good lookout at all times and give way to landing gliders.
- Don't drive on the runways or across grass areas unless you are towing a glider.

Flying

You will have noticed that flying is a team effort. To get a glider in the air we need at least:

- An instructor in charge.
- A winch driver.

- A signaller, who will also attach the cable.
- A log keeper.
- A wingtip holder.
- And a pilot.

On windy days we will need further people to assist with the ground handling of the glider.

New members can help with several tasks at the launch point fairly soon after joining. Like most other jobs however, you need someone to show you first of all.

Cables

First a note about the launch cables, which can be very dangerous if not treated with care. We have two cables on our winch and they are brought to the launch point by the cable tow out truck. The truck will get to the launch point, stop and then reverse a short distance to take the tension out of the cable. At this point someone needs to detach the cables from the spreader arm and leave them on the ground. The spreader arm is then swung forward to latch on the truck. Make sure it's latched properly – driving away with an insecure spreader arm could be disastrous.

The cable nearest the runway is used first and dragged across to the glider that requires it. The remaining cable must be left at the side of the runway. When a launch is in progress do not touch the remaining cable. If for some reason the cables are overlapping then the remaining cable could be dragged away as the launch starts.

We often run with a two winch operation meaning four cables are in use.

Wingtip holder

This person holds the glider wings level at the start of the launch. As the glider accelerates run with the wingtip and let it go when you can't keep up. Never hold on to the wing as dragging it back will turn the glider and make life difficult for the pilot.

Signaller

This person is in charge of the launch and usually has the job of attaching the cable to the glider. Their first task is to check that the weak link on the cable is appropriate for the glider being launched. They are colour coded and many gliders have a label or sticker near the belly hook showing the required link colour. Otherwise the pilot will know what weak link is required. It's also

sensible to check at this stage that all the shackles are tight and that the splices and parachute are in good condition.

The pilot will then ask for the cable and should pull the release knob so the launch ring can be inserted into the hook. If they forget this then you need to shout “open” at them. When you’ve got the ring in the hook shout “close”. Stand up and give the rope a good pull to make sure the cable is attached securely and say “cable on and secure” to the pilot. Then ask the pilot “are your brakes are closed and locked”. Make sure you get a reply that indicates they are and then move to one side of the glider – you don’t want to be hit by the wing tip as the glider launches.

You then need to check that it is all clear above and behind. Check for other aircraft on the approach and directly above the launch point. In some situations, it is OK to launch with a glider on the approach but we must not launch if it is at all possible that the landing glider will end up in front of the glider you are about to launch. You also need to be aware of any gliders low in the circuit or in unusual positions whose pilots may be running out of options with their circuit planning. When looking for other aircraft make sure that nothing is hidden behind the bus. When you are sure all is clear shout “all clear above and behind”. It’s also worth pointing out any other gliders that are in the vicinity of the airfield because the pilot may not have seen them. You need to look to both sides of the airfield and in the release area for powered aircraft incursions and soaring gliders.

Now you can start to signal take up slack. You do this by shouting “Take Up Slack” and waving your arm below your waist. Check that the log keeper on the bus has seen your signal and is actually flashing the lights.

When the cable goes tight, and just as the glider is about to move, signal all out by shouting “All Out” and waving your arm above your head. Continue to signal until the glider is in the full climb.

If at any time you need to stop the launch then shout “Stop Stop Stop” and hold your arms above your head. Anyone at the launch point is entitled to give this signal if they see a problem. There are also ‘emergency buttons’ on the side of the bus which will activate the stop lights.

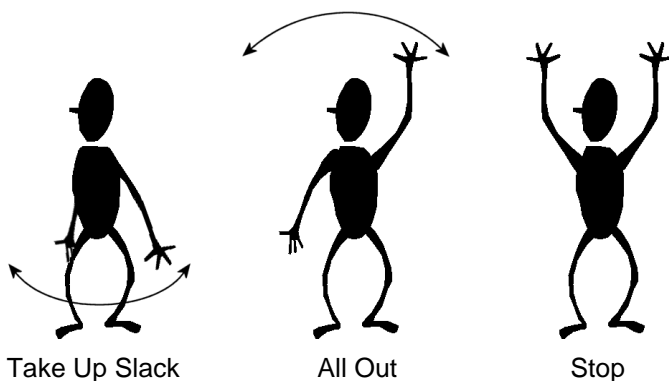

Log Keeper

The log keeper sits at the front of the upper deck on Charlie and is responsible for recording flight details and for relaying signals from the signaller to the winch via the lights and radio.

The flight log is a legal requirement and also used by the club to charge members for their flying. Filling in the log is a good way to get to know everyone's name.

There is a control panel for the lights and radio. It looks complicated but it's really quite simple. Get someone to show you how it works.

Retrieving gliders

When a glider has landed it will need retrieving from the landing area. Depending where the glider has landed we either manhandle the glider back to the launch point or use one of the retrieve vehicles to fetch it. Take care when walking or driving onto the landing area because other gliders may be landing.

Your turn to fly

While you are busy doing all these jobs you need to keep an eye on the flying list. Make sure you are at the launch point when it's your turn and have your logbook and progress card with you. Your instructor will need these to plan your flights.

Putting kit away

At the end of the flying day everything needs to be put away. The gliders are frequently flown back to land on the grass in front of the hangar. The bus, tow

car and other vehicles are driven back. The people doing this will need a lift back to the launch point to get their cars.

Important things to remember are:

- Put the parachutes back in their correct bags and return them to the rack in the tower. They must not be left in the bus or in a glider where they will get damp.
- Connect the charging cable to the bus.
- Take the log sheets from the bus and leave them upstairs in the tower. Members will come here to find out their flight times and pay their launch fees.

Progression

During your initial training your instructors will use your logbook and progress card to record your development. Eventually the time will come when you will be sent solo. You cannot fly solo until you are 14 but it's quite common for people to go solo on their 14th birthday. Your training doesn't end here however. After your first solo you will have one or more check flights on each day you fly. On some days you may find that weather conditions or other circumstances mean that you are not allowed to fly solo. Your first ten or so solo flights will be in the PW6 two seat trainers. After this you will be converted on to a single seat glider. Over the weeks you will gain more proficiency, getting experience of different weather conditions and eventually will be allowed to fly without a check flight that day.

Gliding Awards

Glider pilots should also apply for a FAI gliding certificate issued by the BGA, which is used to record the badges obtained by the pilot. These are:

- 'A' badge. Awarded for a single solo circuit followed by a satisfactory landing and knowledge of the basic rules of the air.
- SPL Sailplane Pilot's Licence

There are further awards for greater achievements, full details of which are in Laws and Rules for Glider Pilots and on the BGA website – www.gliding.co.uk

Winch Driving

Every solo pilot should train to be a winch driver. There is a list of winch instructors in the tower.

Owning your own glider

At some point in your gliding career you are likely to want to buy your own glider, although here is little reason to do this before you have your Bronze 'C' badge. Gliders are usually owned by syndicates of two or more people to help spread the cost of ownership. The decision to buy a glider should be taken after consultation with the Chief Flying Instructor. You will quite likely never have flown the type of glider you will be buying and therefore your decision needs to be approved by the CFI. If the glider is being brought onto the airfield from elsewhere you must also get permission from the club committee.

Competitions

Gliding competitions usually consist of a race round a pre-declared route set by the competition organisers. There are competitions for all standards of

pilots but the minimum qualification is the cross-country endorsement. The following competitions are open to relative beginners:

- Club task week. A low-key competition for club members. Two seat gliders are available for members without the cross-country endorsement.
- Inter-club league. A competition between clubs on a regional basis. We are in the Rockpolishers league with 5 other local clubs. There are three classes for competitors with different experience levels.
- Junior Championships. Heavily subsidised and open to anyone with Silver 'C' and aged under 25. Two seat places are available for pilots without Silver 'C'.

Official Observers

Every gliding achievement and badge claim is scrutinised by an Official Observer. There are several in the club, their names are in the Flight Operations Room and on the web site. The club always welcomes anyone who is willing to take this responsibility. To qualify you need to have been actively involved with gliding for the last three years or have Silver 'C' or an instructor rating. Application forms are available on the BGA website.

Helping out

As you can imagine, the running of the gliding club requires a lot of work by volunteers. Regardless of your skills there will be something you can do for the club. Please look for opportunities to help out and volunteer.

Evening Flying

One area where you can help out is with evening flying. Every Tuesday and Thursday evenings during the summer we fly trial lessons and mini-courses. This provides a vital income to the club and flying these people in the evenings helps relieve the pressure at the weekends when club members want to fly. We frequently have groups of people from work places, clubs and societies and often a barbeque is organised afterwards. This is a very sociable and pleasant way to spend an evening.

Further Information

Flight Operations manual

The Flight Operations Manual expands on the information given here and must be read and signed by all members. Copies are kept in the Briefing Room, on the Bus and in the Office. It is also available online.

Books

Many books have been published on gliding. The club sells some of these – see Susi in the office, the BGA sells them by phone and on their website, and they are of course available to order from bookshops. The local libraries have gliding books.

Sailplane and Gliding

A bi-monthly magazine published by the BGA, which you can order through the club office. You are strongly recommended to subscribe.

World Wide Web

The Web has an enormous amount of information on gliding. A good place to start is the club web site at www.cotswoldgliding.co.uk. Go to the links page and explore from there.

Club Social Activities

The club also has an active social side with regular events throughout the year including –

Themed dinner evenings, BBQs, wine tastings, bonfire night party and an annual club dinner and awards evening.

Club members and their friends and families are encouraged to come along to these events and to make use of the bar and club room after flying.

Here you will hear of the epic flights and other events of the day including many “ How I dunnits”

Glossary

Barograph	An instrument that records air pressure over time. We carry these in gliders to give a trace of our height during a flight that can be used to verify that a flight was completed as claimed. Essential for badge and competition flights. The more modern solution is with an electronic logger.
Lift	Air that is rising faster than the glider is descending and makes the glider climb.
Reduced Sink	Air that is rising, but not as fast as the glider is descending. This delays the descent of the glider.
Sink	Air that is descending. Best avoided.
Turn Point	When flying cross-country we normally set a task (a route) around which we fly. These are frequently triangular but can be a simple out and return or a more complicated quadrilateral. The turn points define the task. The BGA has a set of turn points whose position is accurately known. They are normally easy to recognise features such as road junctions. BGA turn points are referred to by three letter trigraphs and to describe a task all you need to do is list the turn points. For instance, 'AST WAT BAS AST' is a 300km task from Aston Down to Watford Gap services on the M1, then to Basingstoke and back to Aston Down.
Beat-Up	Otherwise known as a practice competition finish. Involves flying the glider close to Vne down to just above ground level. After flying level for a short while the glider is climbed, exchanging speed for height, so that a normal landing can be made. Exciting when done properly.
Get Away	Managing to find lift after the launch and therefore stay up.
Fall Down	Not finding lift and landing.
Retrieve	Fetching a glider that has landed out.
Land out	Landing a glider away from the airfield or intended goal.
GPS	Global Positioning System. More correctly known as GNSS (Global Navigation Satellite System).
Logger	An electronic black box that constantly records the height and position of a glider during flight. The position is obtained from a GPS receiver and the height from an electronic air pressure measurement. The flight log is secure (it cannot be forged) and can be downloaded to a computer for flight claims or analysis. More sophisticated loggers allow an electronic declaration to be made, eliminating the need for an official observer before the flight.
Polebending	Pulling hard on the stick (pole) while winch launching to get maximum height. Not always effective, especially if the weak link breaks.
Bronze Leg	The Bronze badge has several requirements. Each of these is called a 'leg'.
C of A	Certificate of Airworthiness. Similar to an MOT for a car.
P1	Pilot in command, frequently the instructor.
P2	Second Pilot
Rockpolishing	Flying close to hills or mountains. Sometimes necessary to get the benefit from hill lift.
Declaration	A statement made before a flight about the task to be flown. Many

Goal	badge flights require a flight to be completed as declared.
Distance	A flight where a predefined destination, the goal, is declared.
Vne	A flight where the distance flown is important. It's not necessary to reach the goal for the flight to qualify.
Yaw String	Velocity never exceed. The maximum permitted speed of a glider. Flying faster than this is foolhardy in the extreme.
	The bit of string stuck to the canopy of all gliders. Indicates the direction of airflow over the glider.

Anatomy of a glider

